

Aplicaciones de Apoyo a la Gestión

“VII Seminario de Informática en la UC”

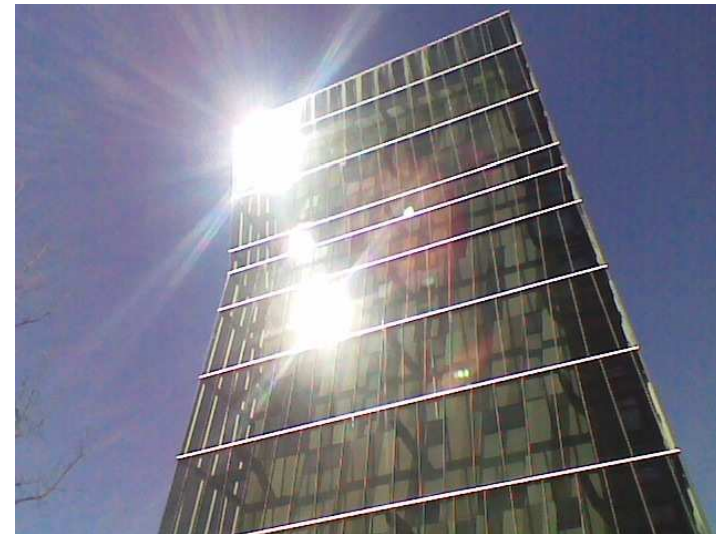

Iñigo Meza H. – Subdirector de Innovación Tecnológica
Dirección de informática
Junio 2009

Aplicaciones de Apoyo a la Gestión

Temario

- *Administración de ancho de banda Internet*
- *Salas Crisol: Administración de impresión*
- *Seguimiento de solicitudes a DI*
- *Gestión del Consumo telefónico (celular).*



Administración de Ancho de Banda Internet

- Estadísticas
- Aplicaciones
- Normativas

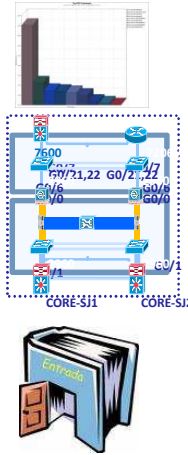

Ancho de Banda INTERNET tendencias

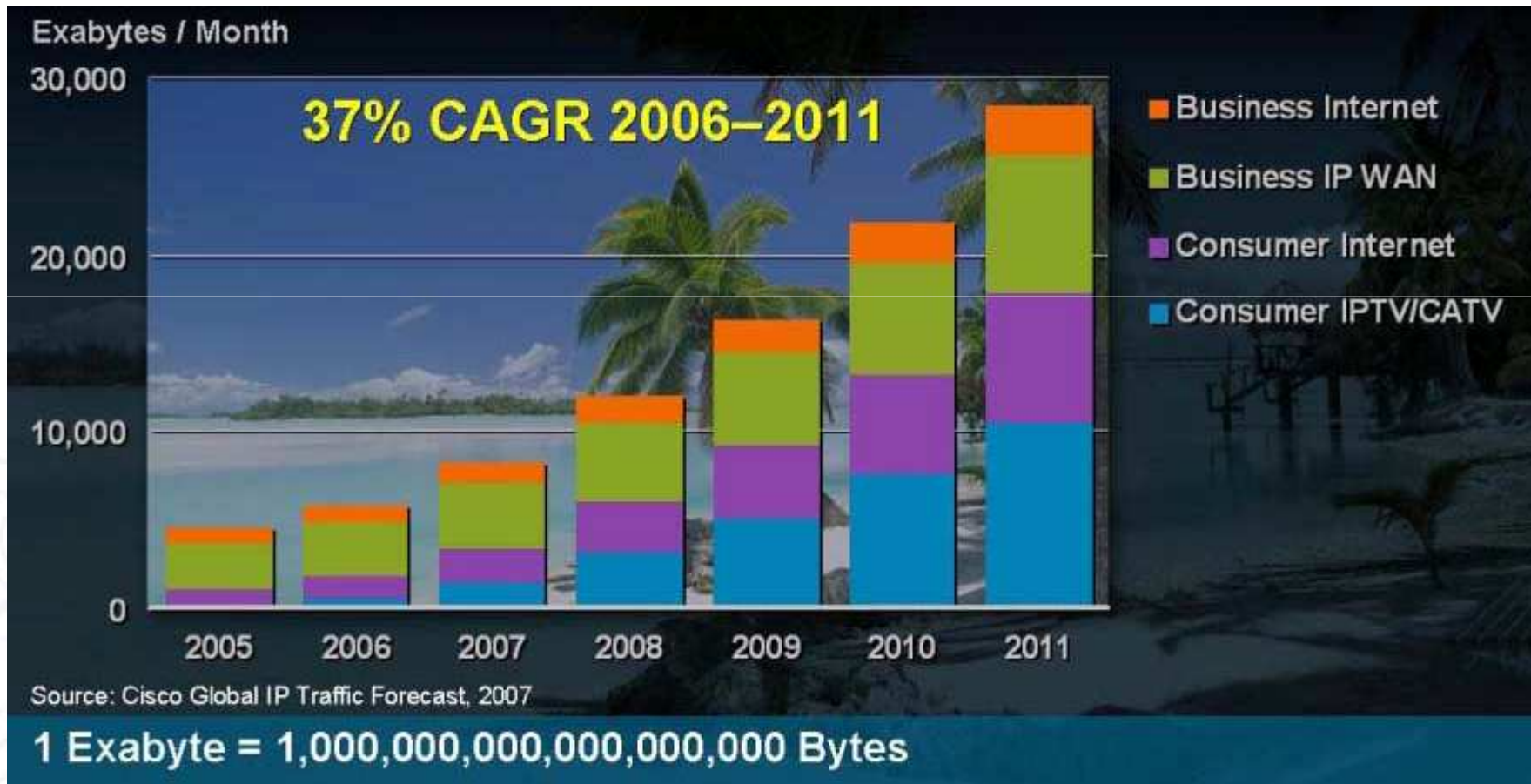

Ancho de Banda INTERNET tendencias

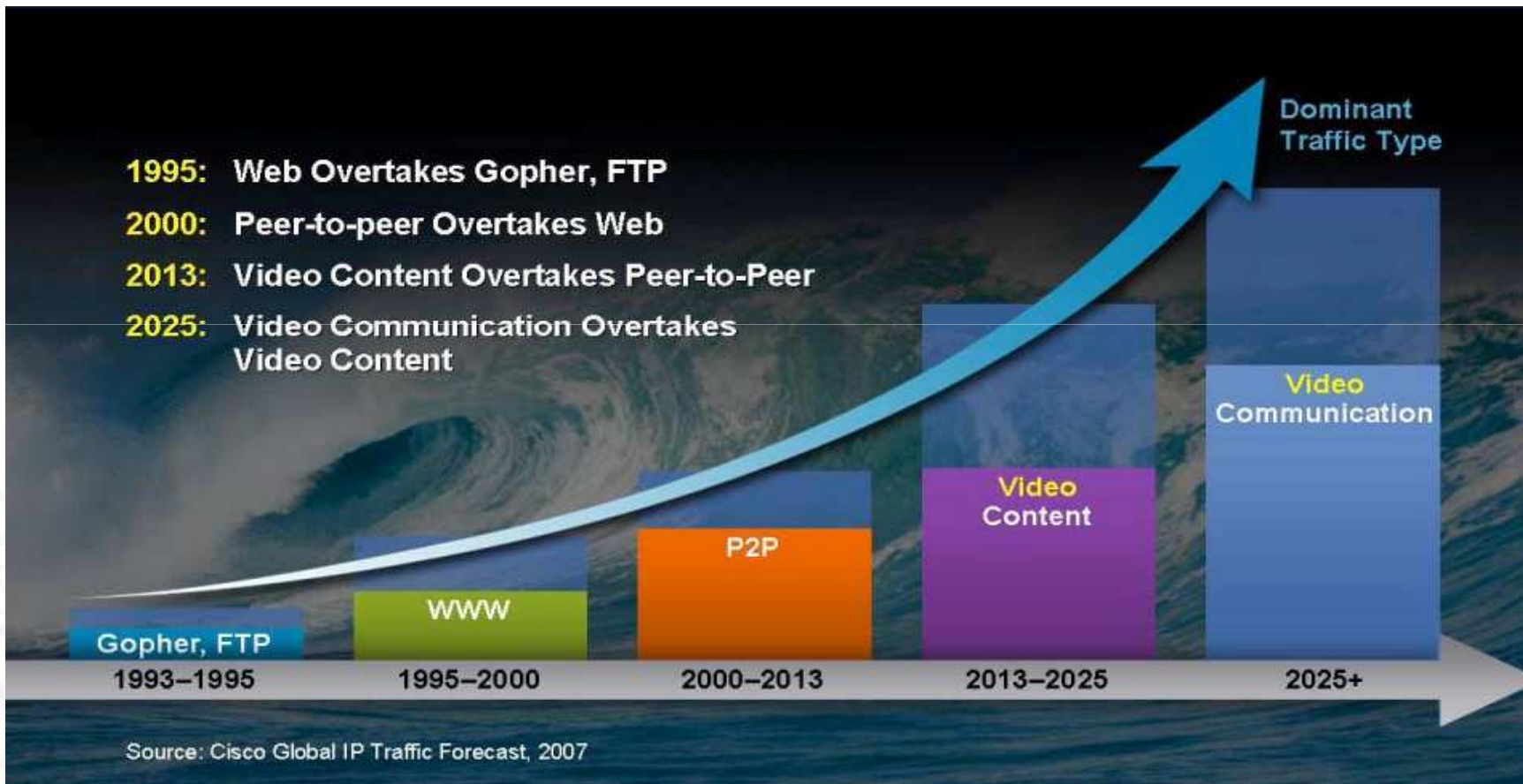

Ancho de Banda INTERNET internacional

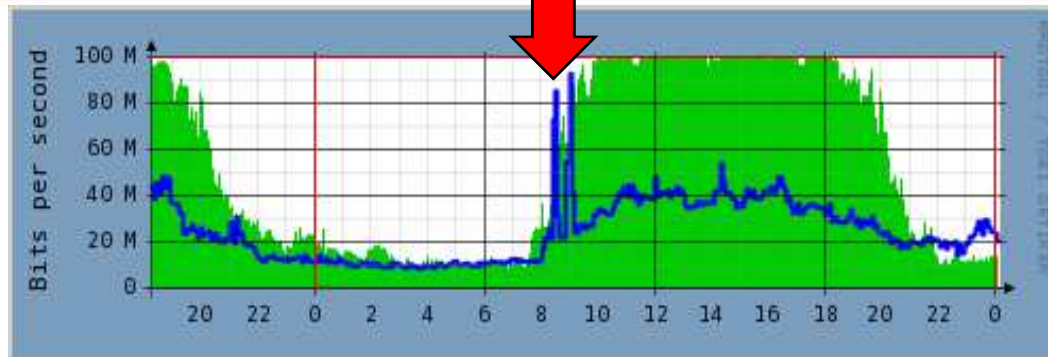

DIA

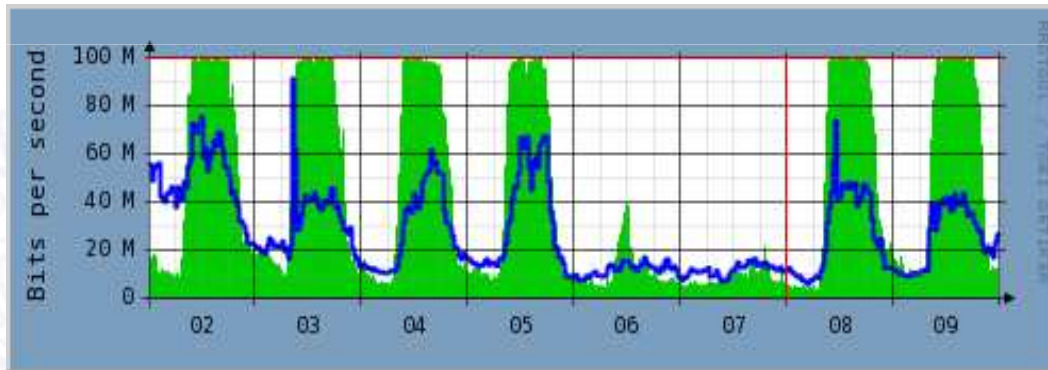

SEMANA

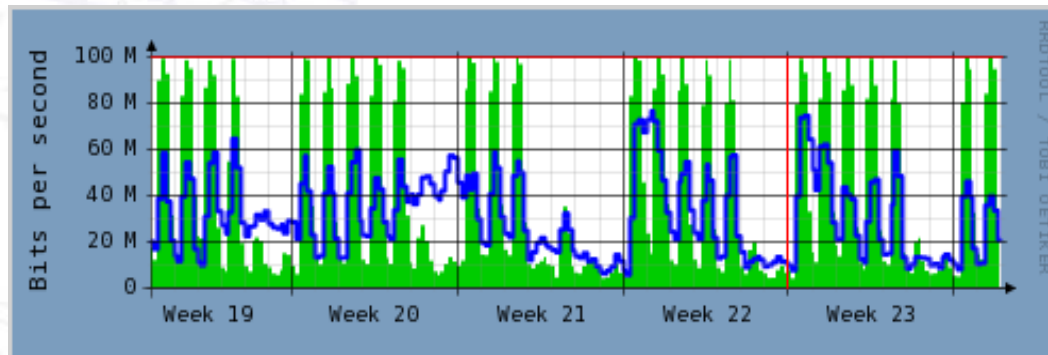

MES

Administración Internet UC: Arquitectura

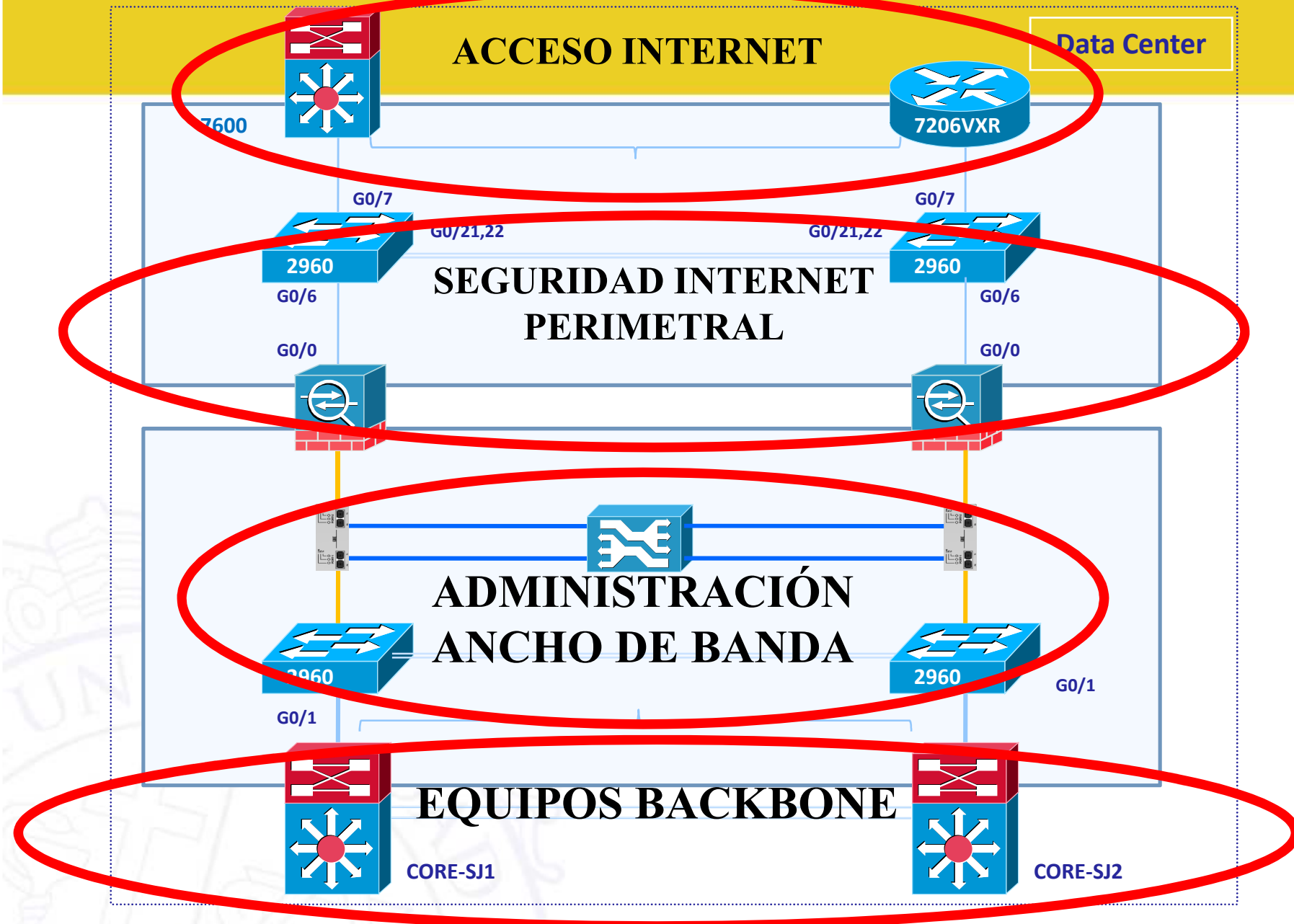

Administración del Ancho de Banda Internet TOP 10

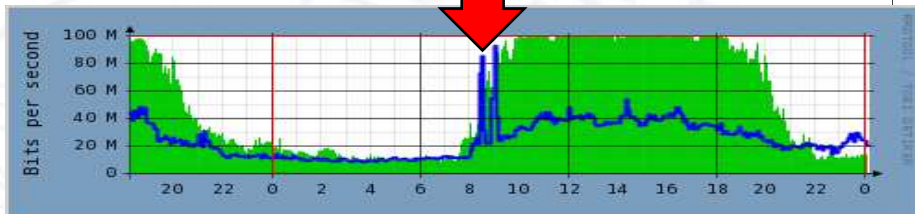
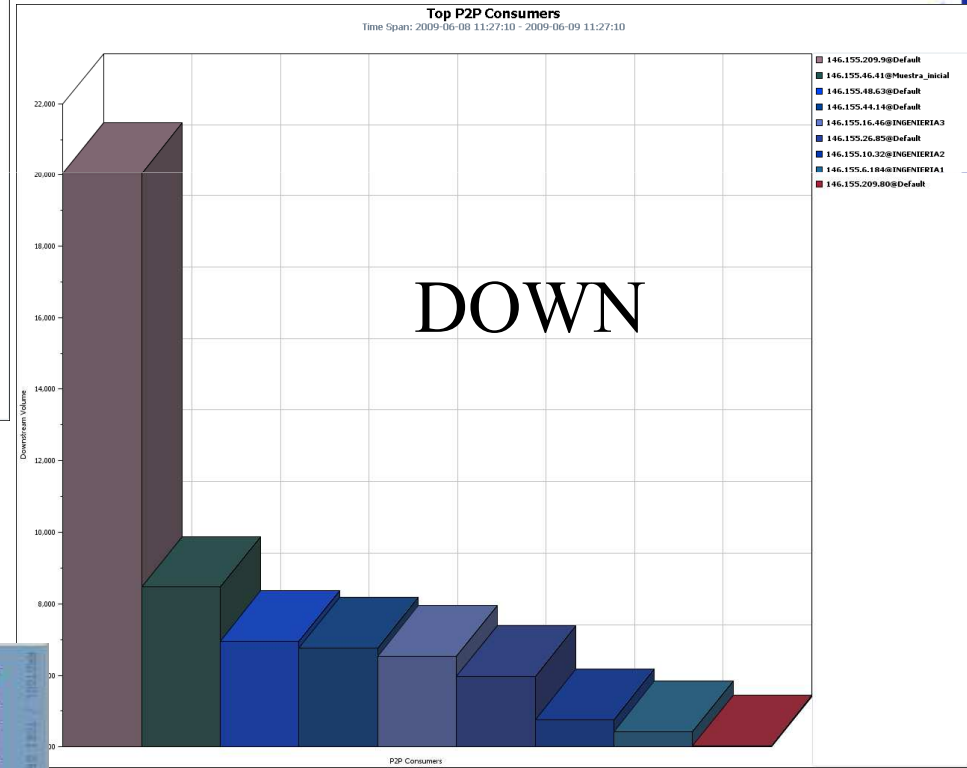
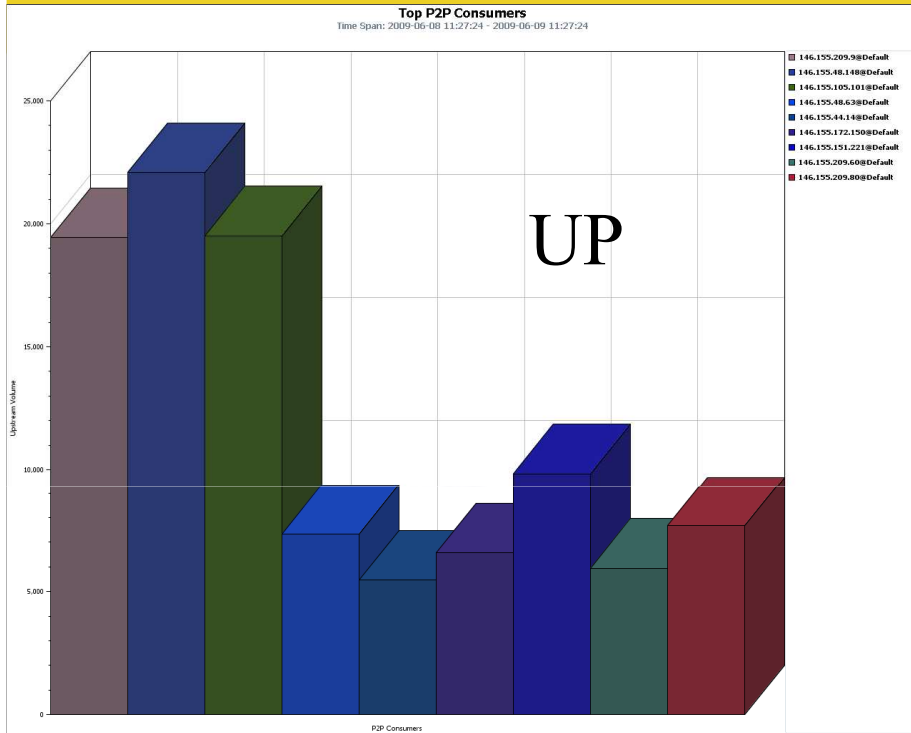

Administración del Ancho de Banda Internet UP

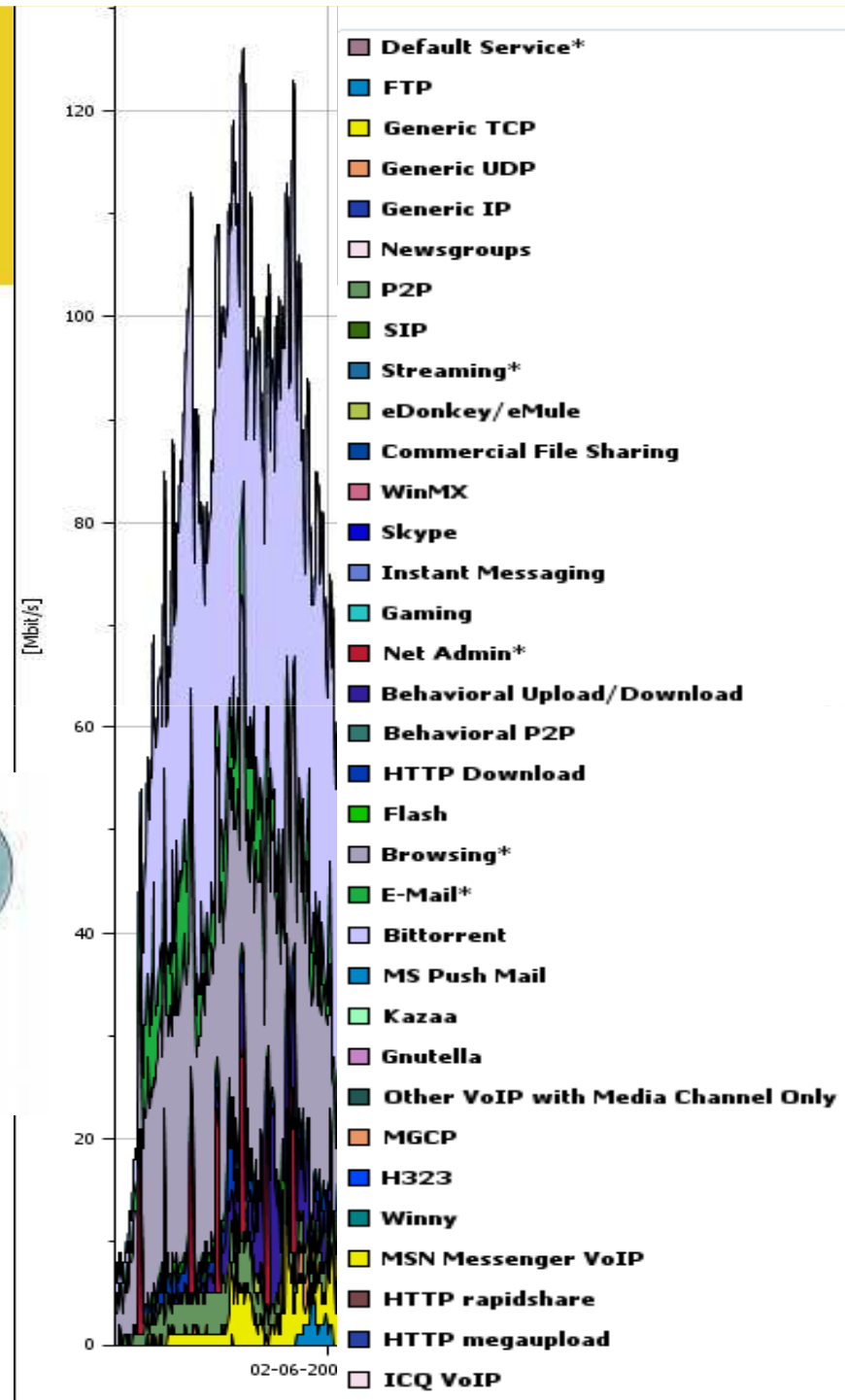
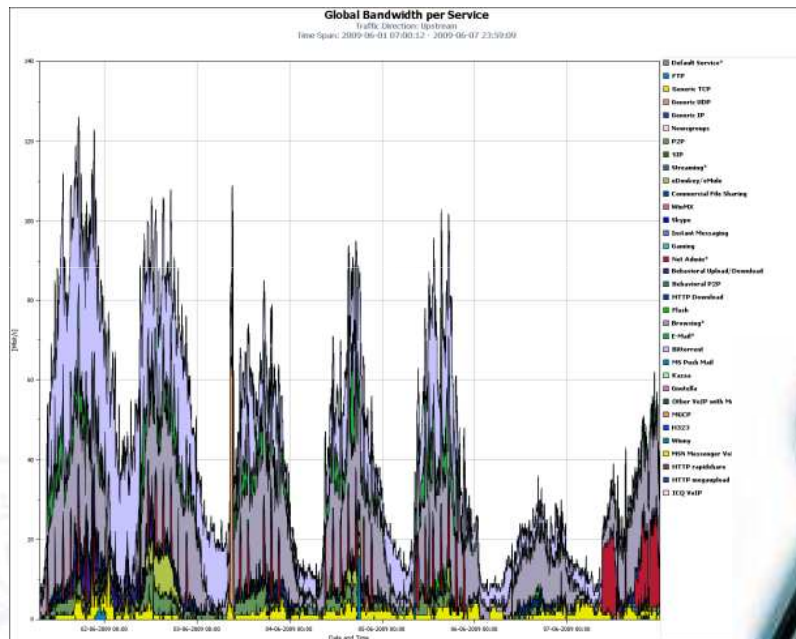

Administración del Ancho de Banda Internet Down

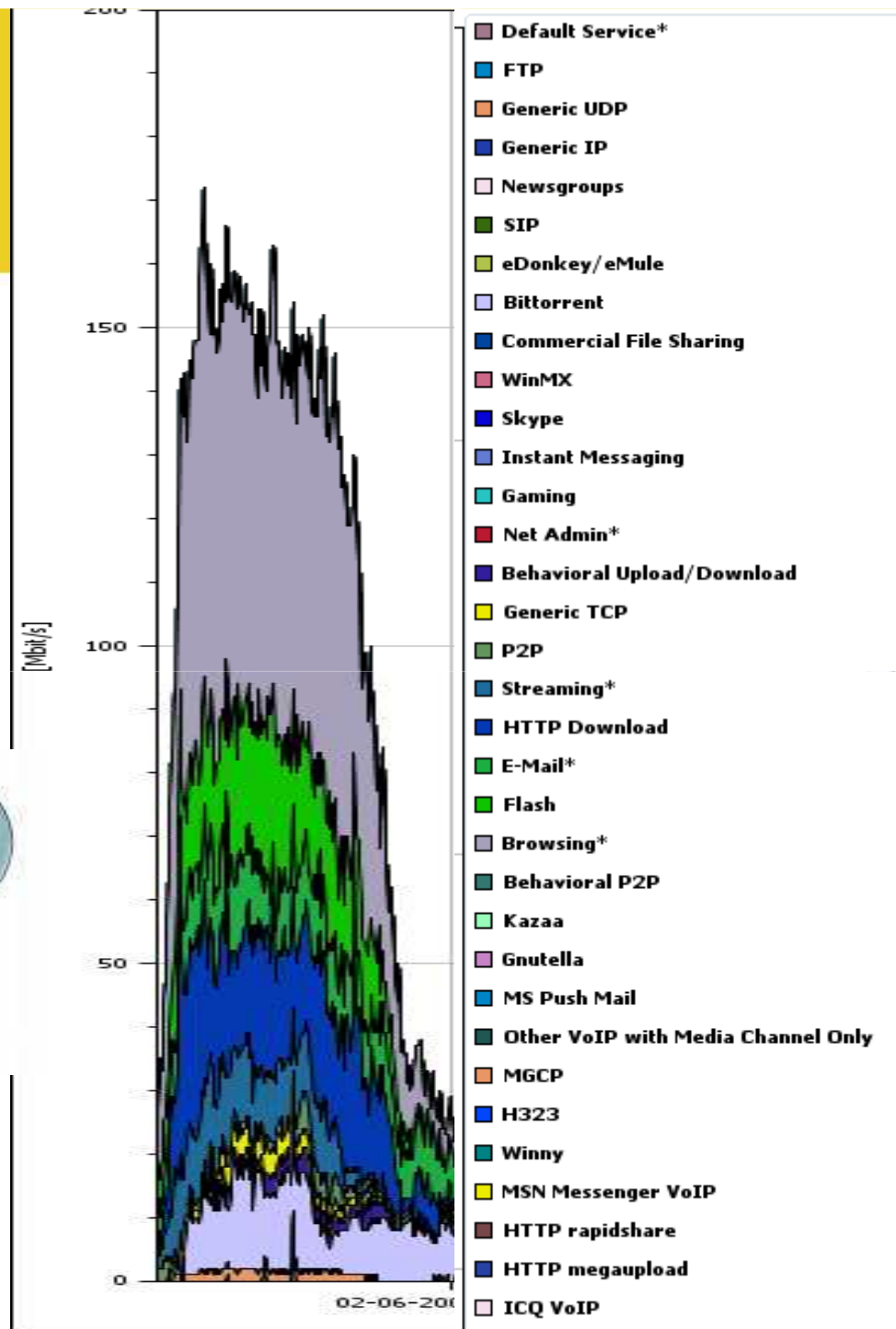
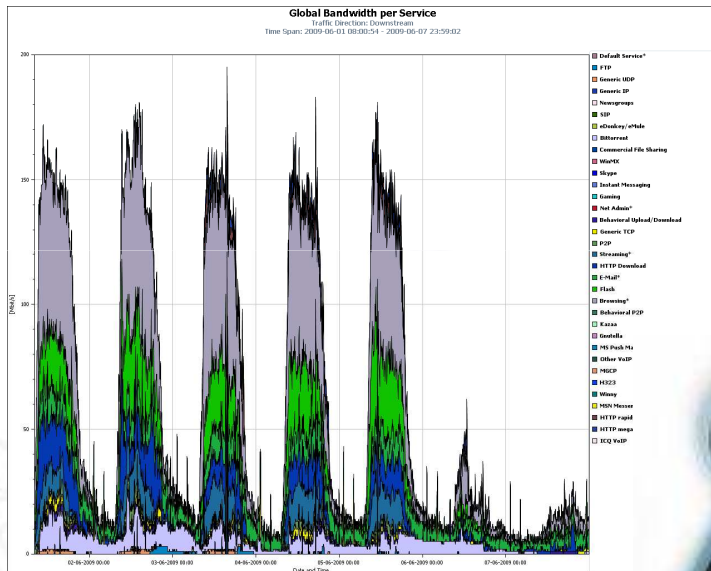

Administración del Ancho de Banda Internet P2P

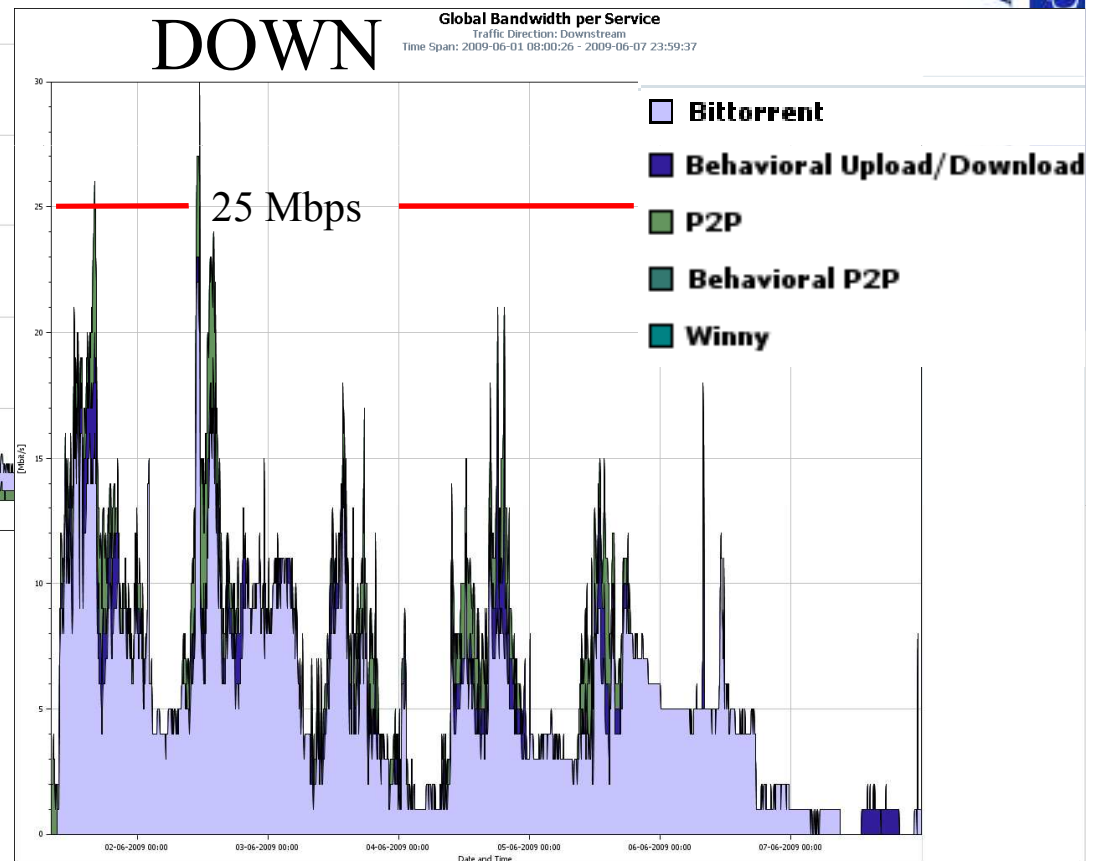
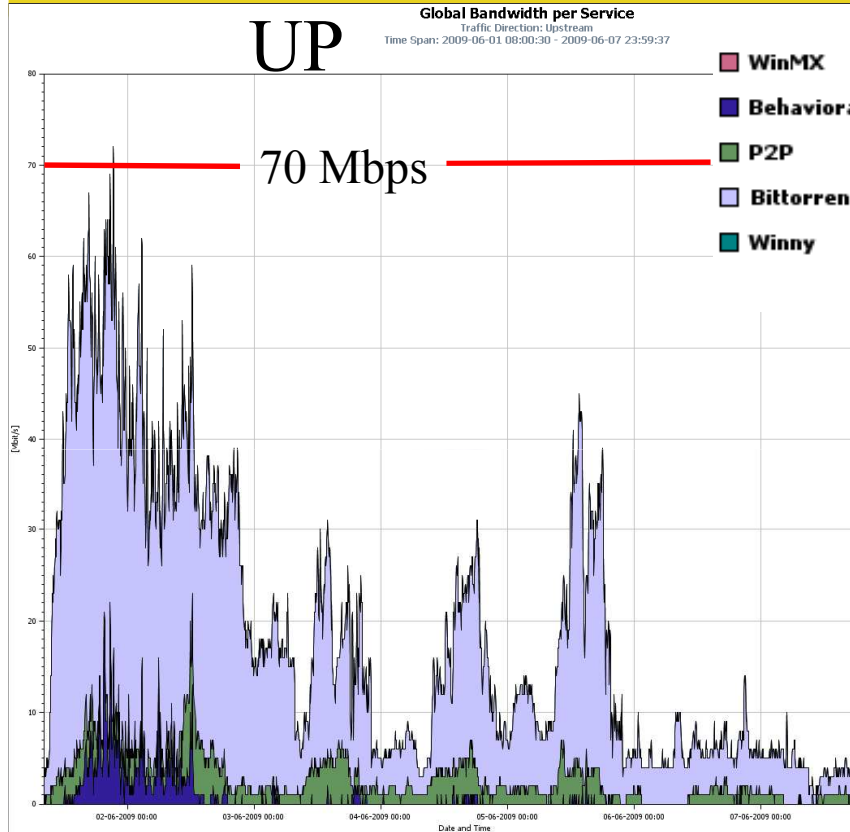

Administrar Ancho de Banda Aporte a Ingeniería P2P

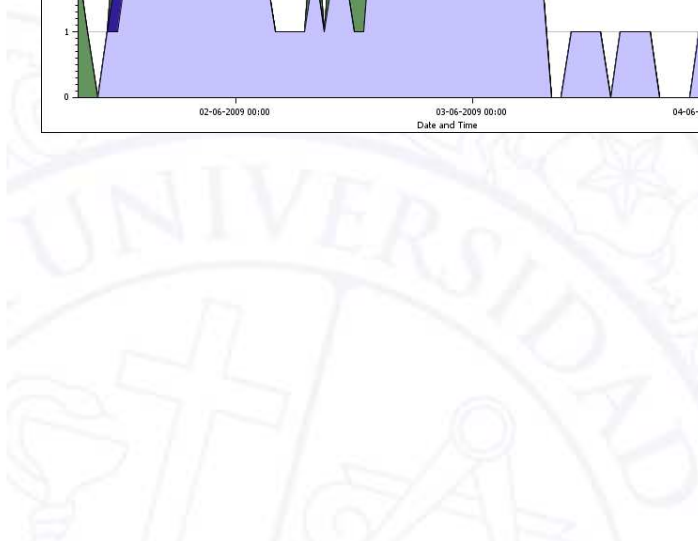
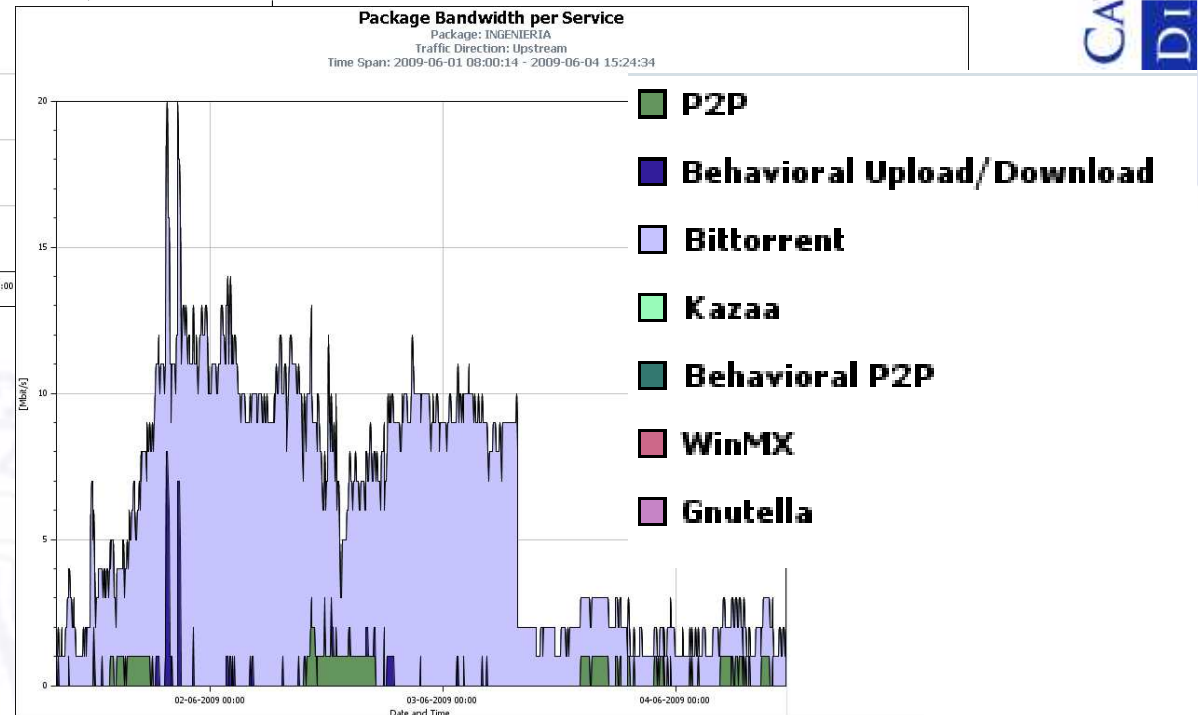
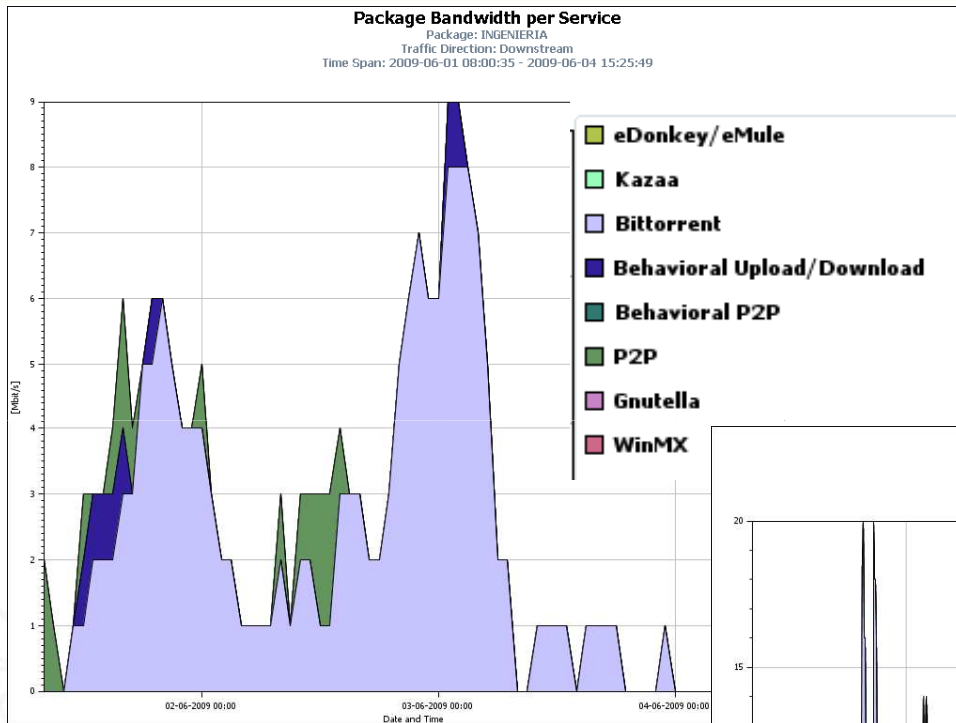

Administración del Ancho de Banda Internet

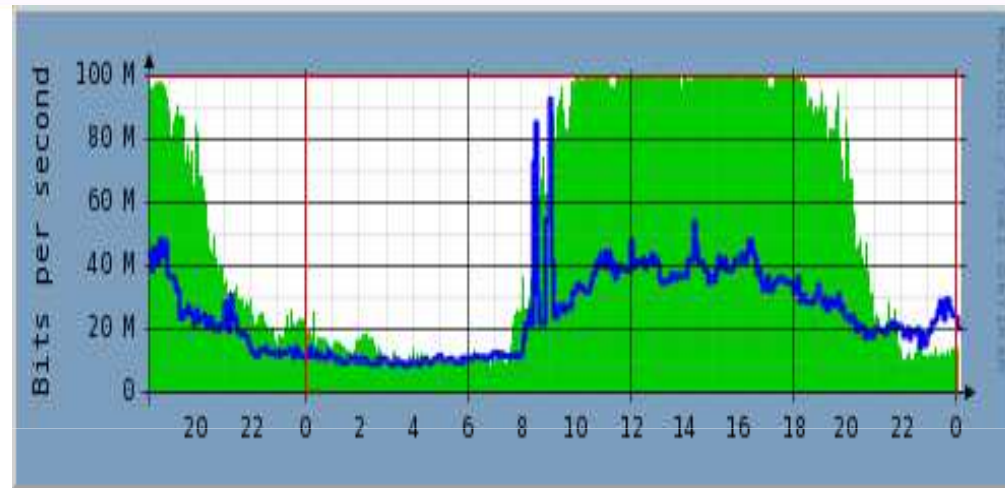
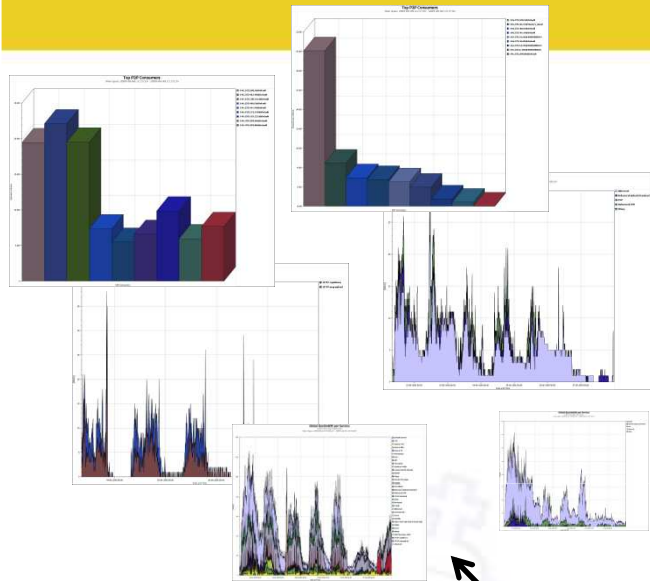

- Estadísticas
- Aplicaciones
- Normativas

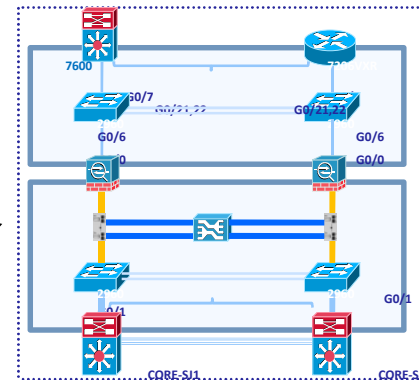

Administración de Salas Crisol



+ 500 PC



Administración de Salas Crisol



Usuario y
Clave UC



Administración
de accesos

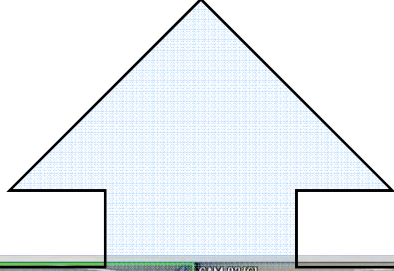

Red UC



Vigilancia

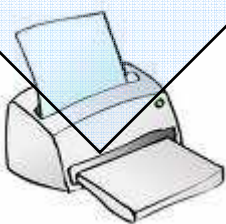

Administración de impresión



Administración de impresión

Sistema de Impresión PaperCut Laboratorios Crisol
Esquema de Funcionamiento.

Area de Soporte

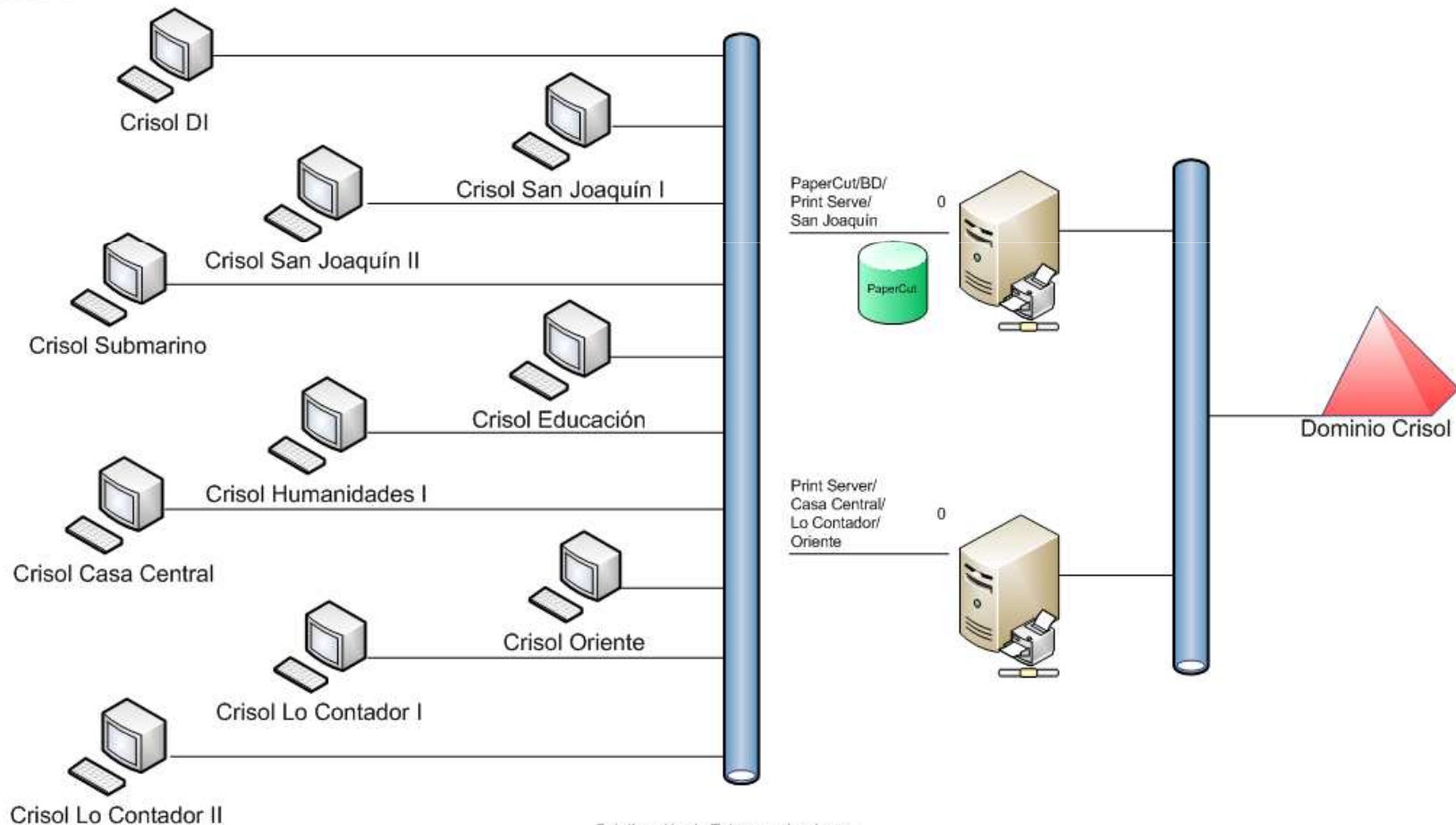

Subdirección de Telecomunicaciones
Dirección de Informática – Pontificia Universidad Católica de Chile

Administración de Impresión



Usuario y
Clave UC

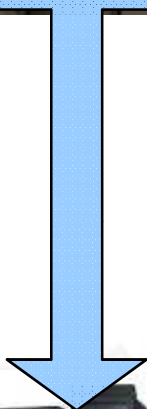

Administración
de accesos



Administración de impresión



Estación de liberación de impresiones

Para comenzar, introduzca sus datos...

Usuario
Contraseña

PaperCut NG 8.3 (Build 5959)

© Copyright 1999-2009. PaperCut Software International Pty Ltd

Administración de impresión

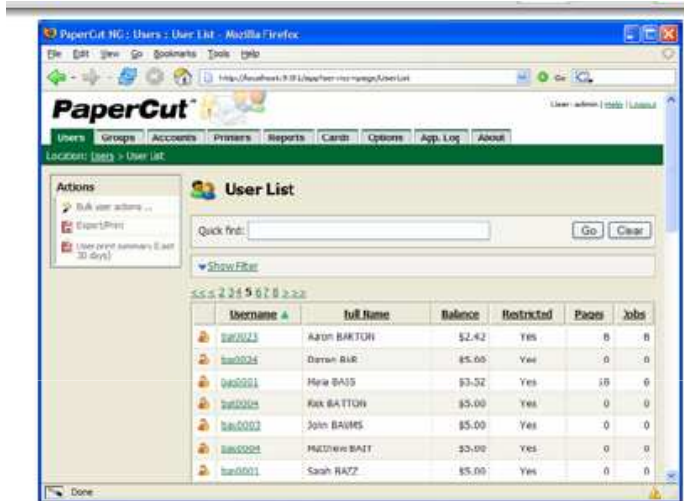

PaperCut NC: Users - User List - Mozilla Firefox

Users Groups Accounts Printers Reports Cards Options App Log About

Location: [http] > User List

Actions

- Bulk user actions...
- Export Print
- User print summaries (last 30 days)

User List

Quick find:

Show Filter

<< < 2 3 4 5 6 7 8 >>>

Username	Full Name	Balance	Restricted	Pages	Jobs
bar0023	Aaron BARTON	\$2.42	Yes	6	6
bar0024	Damon BIR	\$5.00	Yes	0	0
bar0001	Heva BASS	\$3.52	Yes	10	6
bar0004	Rak BATTON	\$5.00	Yes	0	0
bar0002	John BAUMS	\$5.00	Yes	0	0
bar0004	McDrew BAUT	\$3.00	Yes	0	0
bar0001	Sarah RAZZ	\$5.00	Yes	0	0

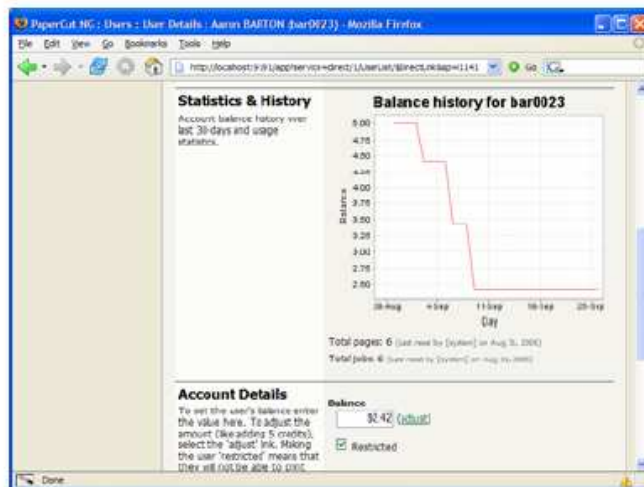
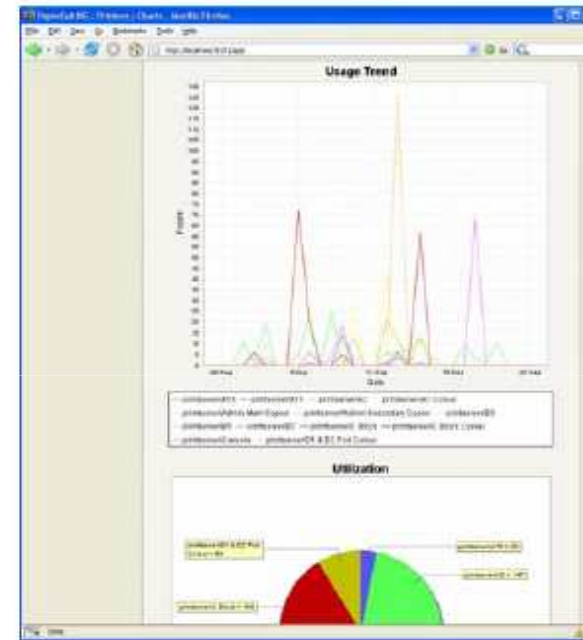

Print Job Notifications

Print Job Notifications

Confirm the print and select the account to charge

Account name: Microsoft Word - bar0023

Printer: VM2002-Carr: 50 2009

Cost: \$0.92

Pages: 10

Balance for checks

Balance for checks

\$0.92

Balance for flock

Balance for flock

\$3.00

Seguimiento de solicitudes



Seguimiento de solicitudes

Modelo de atención

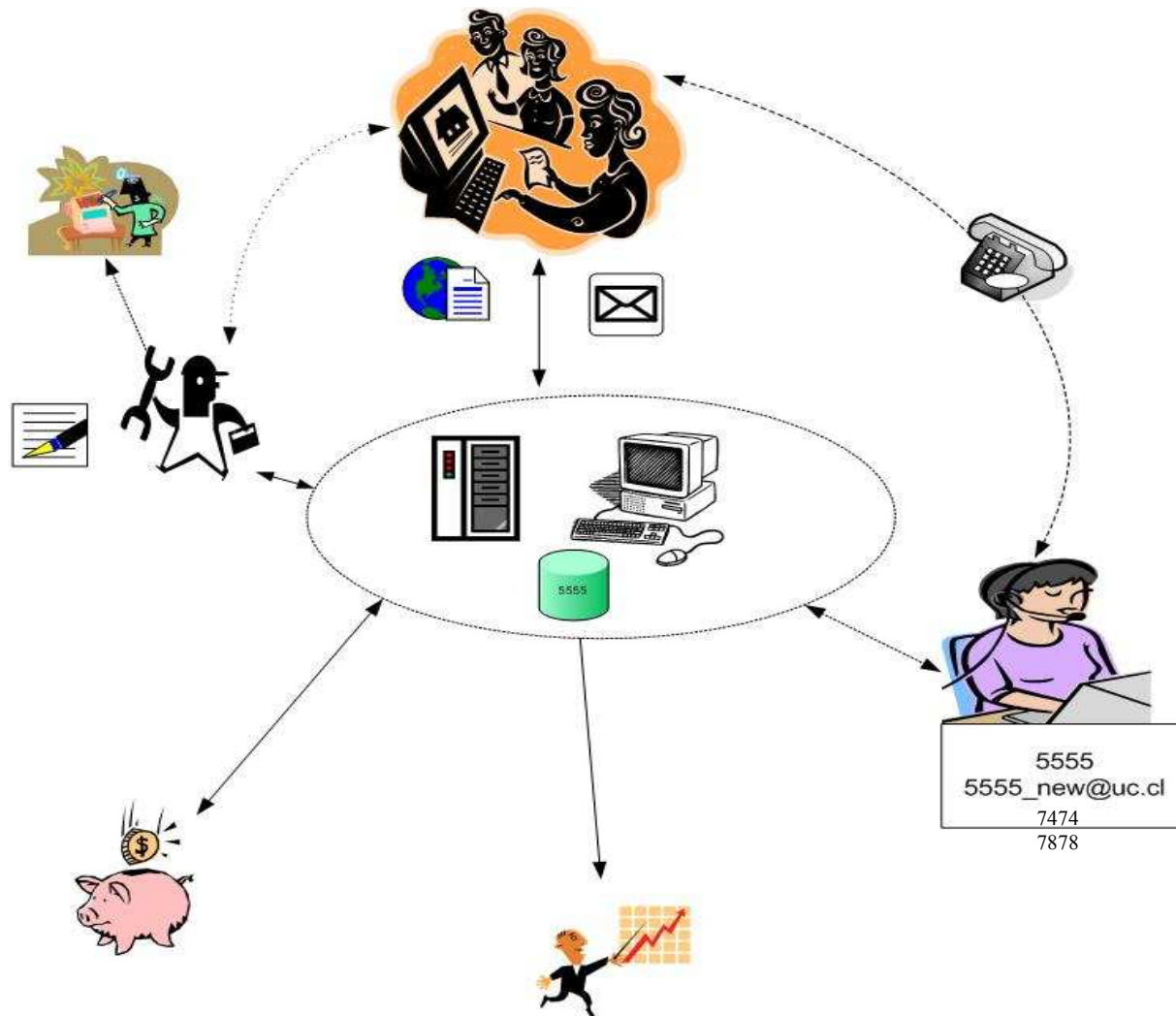

Funcionamiento

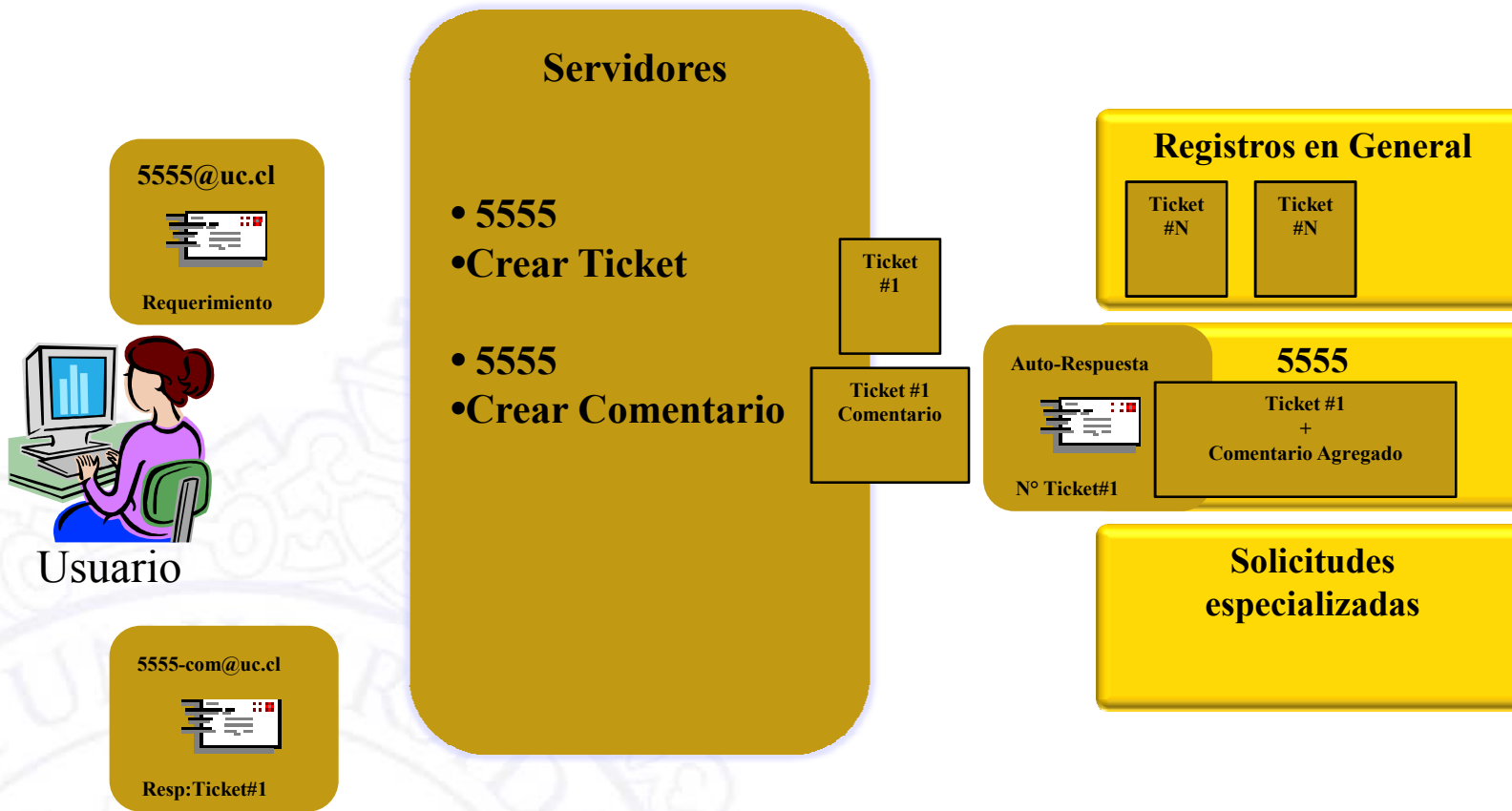

Seguimiento de solicitudes de Soporte en DI

Encontrado 77 tickets

Nueva búsqueda · Editar Búsqueda · Avanzado · **Mostrar resultados** · Actualización en bloque

#	Asunto Solicitantes	Estado Creado	Cola Última actualización	Propietario Actualizado por ultima vez	Prioridad Tiempo Restante
36224	Cotizar pto. de red y eléctrico en 1er piso CDDOC gcastillol@uc.cl	abierto Hace 4 semanas	STS-Teleco Hace 13 días	jecister Hace 38 horas	0 0
38576	Cambio direccionamiento IP central telefónica COR rsandoval@uc.cl	abierto Hace 2 semanas	STS-Teleco	ttapia Hace 12 horas	0 0
38969	Cotización por 5 puntos de red dperezs@uc.cl	abierto Hace 2 semanas	STS-Teleco Hace 11 días	jecister Hace 4 días	0 0
39230	Prototipo planos rsepulve@uc.cl	abierto Hace 2 semanas	STS-Teleco	jhuicham Hace 13 días	0 0
39233	Aplicación reporte Rutas CTC-Mqh rsepulve@uc.cl	nuevo Hace 2 semanas	STS-Teleco	jhuicham Hace 2 semanas	0 0
39410	dar de baja anexo 1283 rsepulve@uc.cl	pendiente Hace 13 días	STS-Teleco Hace 4 días	jhuicham Hace 4 días	0 0

Seguimiento de solicitudes de Teleco en DI

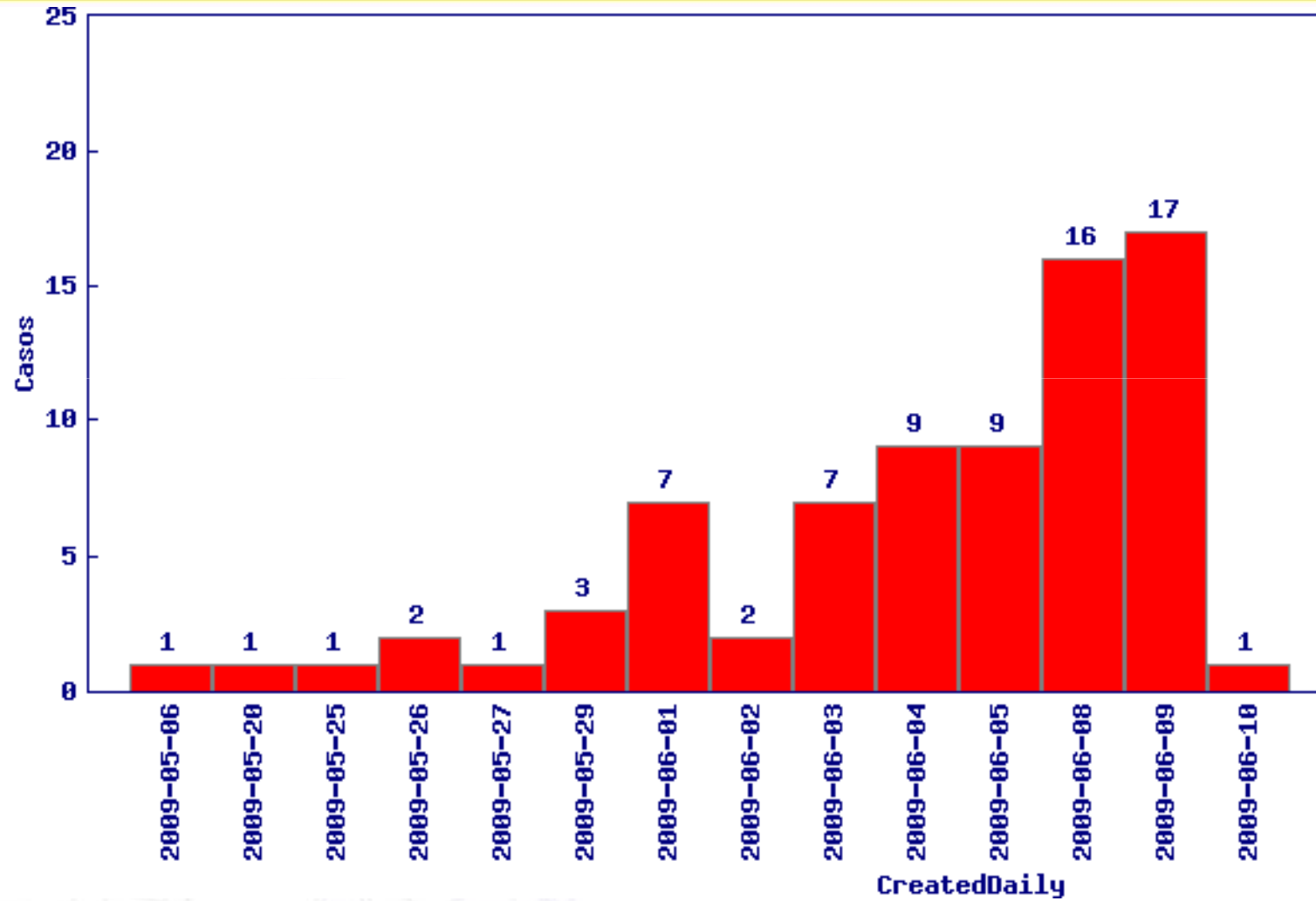

Seguimiento de solicitudes

Modelo de atención

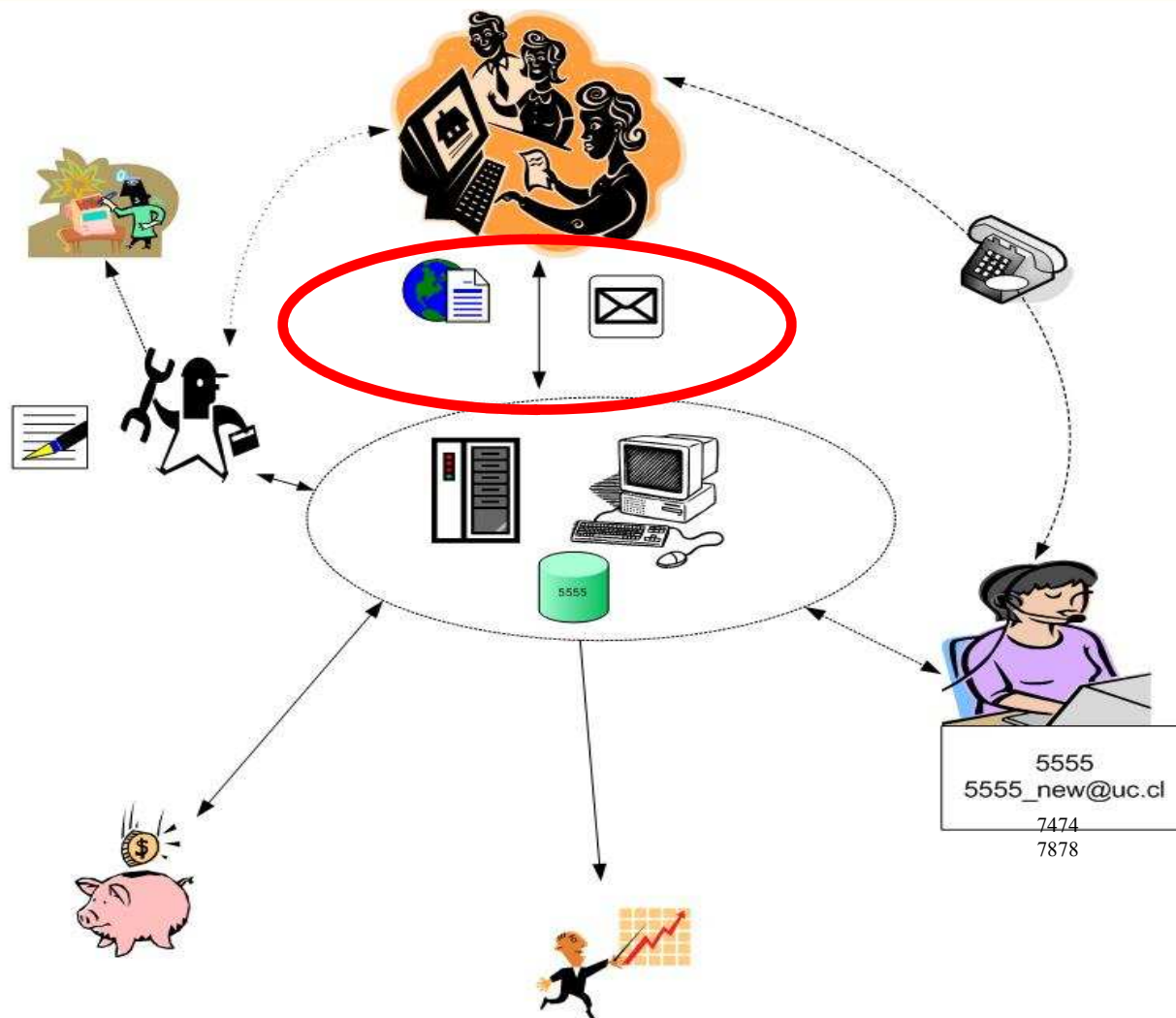

Gestión del Consumo telefónico

+ 6.500 anexos

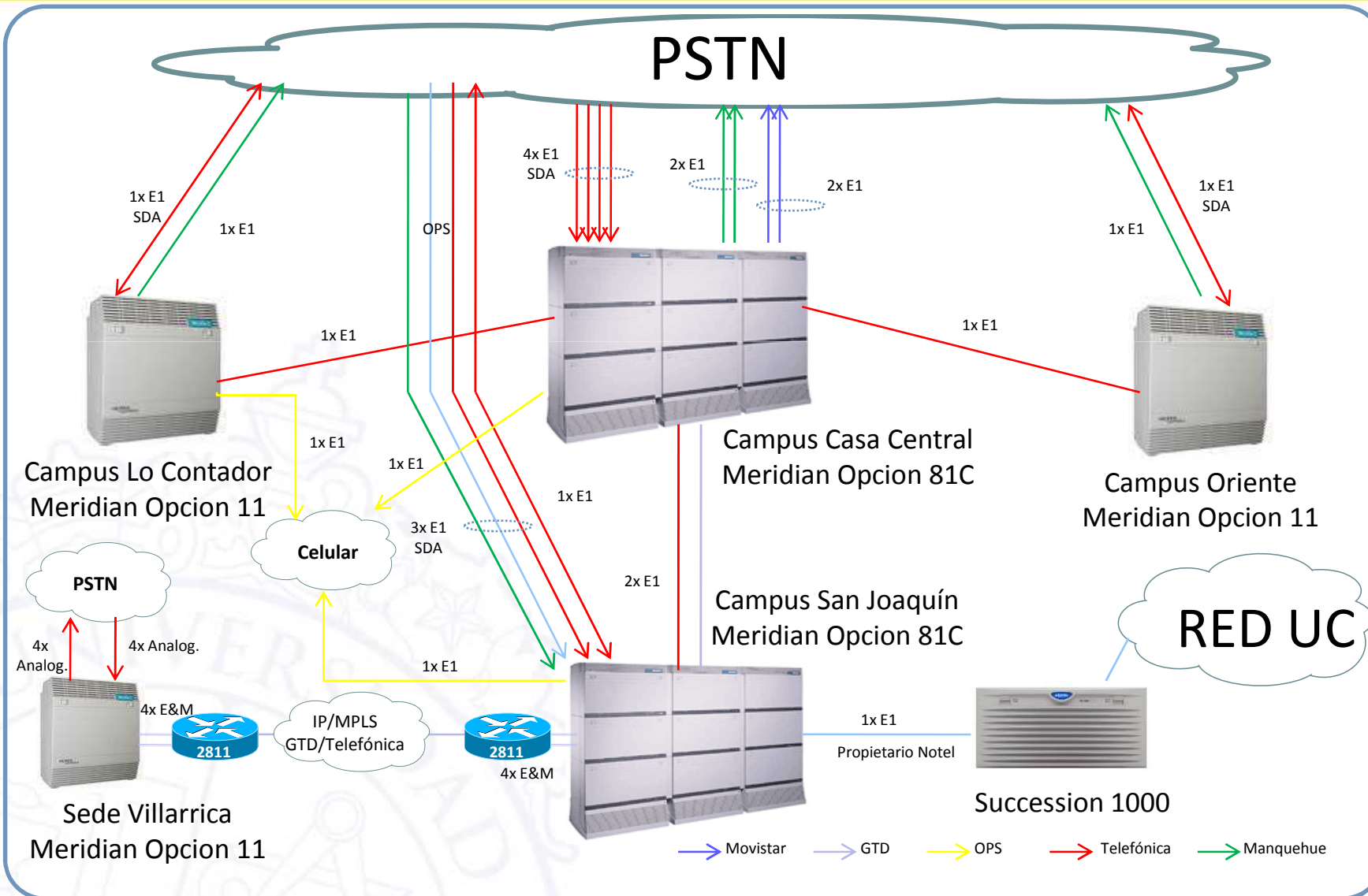

Gestión del Consumo telefónico

The screenshot shows the top navigation bar of the website. On the left is the university's crest. To its right, the text 'PONTIFICIA UNIVERSIDAD CATÓLICA DE CHILE' is displayed. Further right is a search bar with the text 'Buscar contenidos en la UC' and a 'Google' logo. Below this bar is a banner with a blue and orange gradient background. The text 'Sistema de Tarificación Telefónica UC' is written in white and yellow. To the right of the text is an image of a woman talking on a mobile phone, with a grid of numbers overlaid on the background.



Gestión del Consumo telefónico



-
-
-



Cuenta Financial 5812-001-41
Nombre Unidad: Dirección de Informática **Responsable:** Mario Nupallante **Periodo** 04/2009

Entel

DETALLE MÓVILES

PLAN					ESPECIALES	
MÓVIL	USUARIO	CONTRATADOS	EXCEDIDOS	NO INCLUIDOS	TERCEROS	DESCUENTOS
78094729	Victor Ramirez	8.395	6.584	0	0	-156
SUBTOTAL						
TOTAL						

Para Mayo de 2009

la cuenta total de Todos los clientes

la cuenta resumen de Todos los clientes

la cuenta total de Todos los campus

la cuenta del anexo

incluir detalles.

la cuenta de la unidad cuyo código es

incluir detalles solo cobro revertido

Vista desde 2009-06-03 18:05:15

Consumo telefónico

PONTIFICIA UNIVERSIDAD CATÓLICA DE CHILE

Sistema de Tarificación Telefónica UC

Buscar contenidos en la UC

PONTIFICIA UNIVERSIDAD CATÓLICA DE CHILE

Sistema de Tarificación Telefónica UC

Buscar contenidos en la UC

Elija una opción

Obtener en Excel

PONTIFICIA UNIVERSIDAD CATÓLICA DE CHILE
 Código : 80050
 Cliente : Victoria Saud
 Mes: Mayo Fecha de Vencim

DIRECCIÓN DE INFORM

Resúmenes
 Cuentas Período 01/2009

PONTIFICIA UNIVERSIDAD CATÓLICA DE CHILE

Sistema de Tarificación Telefónica UC

Buscar contenidos en la UC

TOTS: 5

ANEXO	SLM
5667	1.448
5671	575
7726	128
7749	1.791
7751	774
7752	54
7797	0

Elija una opción

Cuenta Financial 5812-001-41
 Nombre Unidad: Dirección de Informática Responsable: Mario Nupallante Período 04/2009
 Entel

DETALLE MÓVILES

MÓVIL	USUARIO	PLAN			ESPECIALES			TOTAL
		CONTRATADOS	EXCEDIDOS	NO INCLUIDOS	TERCEROS	DESCUENTOS	NETOS	
78094729	Victor Ramirez	8.395	6.584	0	0	-156	14.823	17.639
SUBTOTAL								17.639

TOTAL

17.639

